

# SOLPAK

## ***OLIVER TRAY SEALER***



## ***Model 1808-CE***

User's operating and instruction manual



## ***Index***

<b>Section description .....</b>	<b>Page</b>
SAFETY INSTRUCTIONS.....	5
NAMEPLATES PART LIST.....	8
NAMEPLATE DIAGRAM.....	10
DESCRIPTION.....	11
INSTALLATION INSTRUCTIONS.....	13
OPERATING INSTRUCTIONS.....	14
OPERATING THE MACHINE.....	16
CLEANING PROCEDURES.....	21
TRAY CARRIER CHANGE PROCEDURE.....	22
TRAY CARRIER SIZE CHANGE.....	23
MAINTENANCE PROCEDURES.....	26
HEAT SEAL ROLL DOWN STROKE ADJUSTMENT PROCEDURES.....	29
TEMPERATURE ADJUSTMENT.....	30
RECOMMENDED SPARE PARTS.....	31
TROUBLE SHOOTING.....	32
FRAME AND DRIVE ASSEMBLY.....	35
LEG ASSEMBLY.....	38
HEAT SEAL FRAME ASSEMBLY.....	39
HEAT SEAL ROLL ASSEMBLY.....	41
DISCHARGE ASSEMBLY.....	43
FILM MANDREL ASSEMBLY.....	45
ELECTRICAL ASSEMBLY.....	47
ELECTRICAL DIAGRAM.....	50
WARRANTY.....	52
WARRANTY PROCEDURES.....	53
A-MANUAL-1808CE-2015-12-11	3



## ***Safety instructions***



**VARIOUS SAFETY DEVICES AND METHODS OF GUARDING HAVE BEEN PROVIDED ON THIS MACHINE. IT IS ESSENTIAL HOWEVER THAT THE MACHINE OPERATORS AND MAINTENANCE PERSONNEL OBSERVE THE FOLLOWING SAFETY PRECAUTIONS. IMPROPER INSTALLATION, MAINTENANCE, OR OPERATION OF THIS EQUIPMENT COULD CAUSE SERIOUS INJURY OR DEATH.**

1. Read this manual before attempting to operate your machine. Never allow an untrained person to operate or service this machine.
2. Connect the machine to a properly grounded electrical supply that matches the requirements shown on the electrical specification plate and follow all specifications of local electrical codes.
3. Disconnect and lockout the machine from the power supply before cleaning or servicing.
4. Check and secure all guards before starting the machine.
5. Observe all caution and warning labels affixed to the machine.
6. Use only proper replacement parts.
7. Do not wear loose fitting clothing or loose hair when working near this machine. Shirt tails should be tucked in.
8. Wear proper personal protective safety equipment.
9. Keep Hands away from the moving parts of this machine while it is in operation.
10. In addition to these general safety instructions, also follow the more specific safety instructions given for the different areas of the machine operating instruction manual.
11. Hazardous energy source: Electricity.



**DO NOT USE FOR OTHER THAN ORIGINALLY INTENDED PURPOSE**

## ***Safety instructions (continued)***



**DO NOT USE FOR OTHER THAN ORIGINALLY INTENDED PURPOSE.**

### **Electrics-Theory of Operation**

Power supply to machine is: 2 line, 1 ground.

Both lines are protected by a 2 pole circuit breaker.

Various electrical control items are protected by fuses in the electrical enclosure.

Heater roll will only heat when **all** the conditions are met;

- Correct power is supplied to machine
- Machine is in Reset condition
- Emergency stop pushbutton released
- Circuit breaker is in reset condition
- Heater roll selector is in the "I" on position
- Temperature control output contact is closed.

Conveyor is started only when **all** these conditions are met;

- Correct power is supplied to machine
- Machine is in Reset condition
- Emergency stop pushbutton released
- Circuit breaker is in reset condition
- Fuses are intact and in place
- Roll in lowered position (operating handle in sealing position)
- \*Safety limit switch is activated – In-feed gate in place
- \*Start pushbutton is momentarily depressed

In the event of a power failure conveyor will only operate after all the above conditions are met. Conveyor will not automatically restart when power is restored.

## ***Safety instructions (continued)***

Heater roll will heat until **any** of the following conditions are met.

- Power supply interrupted
- \*Heater roll selector is in the "O" off position
- \*Emergency stop pushbutton depressed
- Circuit breaker is in tripped (open) condition
- Fuses opened due to short circuit and/or over-current
- \*Safety limit switch de-activated – In-feed gate displaced
- \*Interlock (Reset) circuit activated

Conveyor will operate until **any** of the following conditions are met.

- Power supply interrupted
- Roll in raised position (operating handle in idle position)
- \*Emergency stop pushbutton depressed
- Circuit breaker is in tripped (open) condition
- Fuses opened due to short circuit and/or over-current
- \*Safety limit switch de-activated – In-feed gate displaced
- \*Interlock (Reset) circuit activated

\* = requires operator action

### **DECOMMISSIONING STATEMENT**







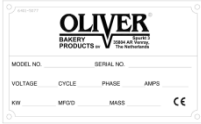

Please dispose of all materials as suggested in the appropriate MSDS reports at the end of this manual, and as required by your state and local regulations.

Remember to always recycle when possible.







**RECYCLE**

## Nameplates part list

ITEM NO	SYMBOL	PART DESCRIPTION	PART NUMBER
709		"OLIVER"	6401-5076
711 712		"STAY CLEAR"	6401-9042 6401-9043
701		"CONSULT MANUAL"	6400-3029
703		"ELECTRICAL SHOCK"	6400-5009
713		"UNPLUG BEFORE OPENING"	6402-1028
708		"NO ACCESS FOR UNAUTH..."	6401-4020
858		"START (OF ACTION)"	6401-9041
856		"E-STOP (Yellow Background)"	6400-5011

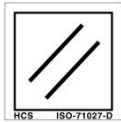
## Nameplates part list (continued)

ITEM NO	SYMBOL	PART DESCRIPTION	PART NUMBER
844		"HEATED ROLL"	6400-8010
704 705 706		"HOT SURFACE"	6400-8020 6400-8021 6400-8022
851		"RESET"	6401-8002
839		"FEED"	6400-6025

## Nameplate diagram

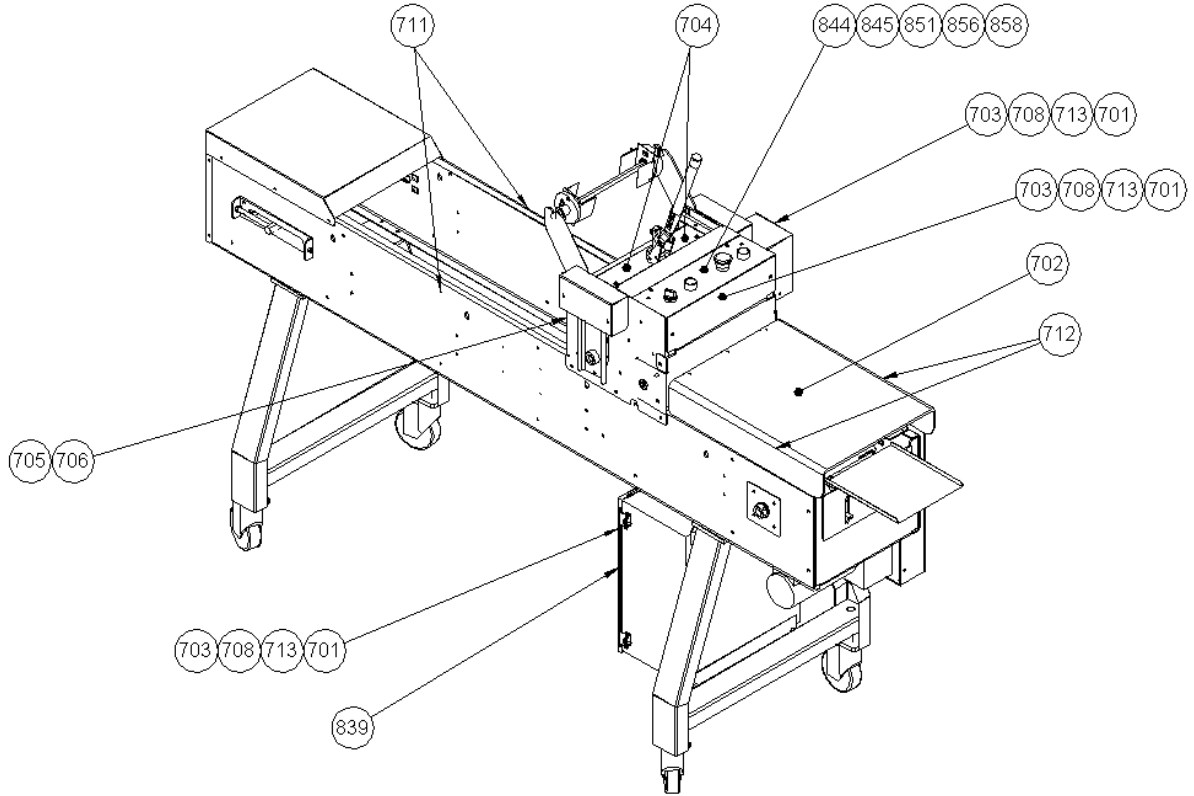

## Description

The OLIVER Model 1808-CE Tray Sealer has been designed and manufactured to provide a machine of very high quality, yet with a cost effective approach to producing film lidded trays. The Model 1808-CE Tray Sealer is designed to heat seal film to paperboard and thermoplastic trays at speeds of up to 35 trays per minute. The machine can be operated wherever an adequate power outlet is available (see power requirements). The machine consists of a continuous motion conveyor system, a film feed station, a heated sealing roll and a film cutter unit. The machine is supplied with casters for ease of relocating. Its design will provide years of efficient, trouble-free operation requiring a minimum of maintenance.

The Model 1808-CE Tray Sealer is of stainless, plated, and painted steel construction for easy cleaning and maintenance.

Oliver Products Company, who has a reputation of serving the Food Industry for over 70 years, backs this equipment.

## Specifications

*Space Requirements:*

**Model 1808-CE** (All Dimensions are Approximate)

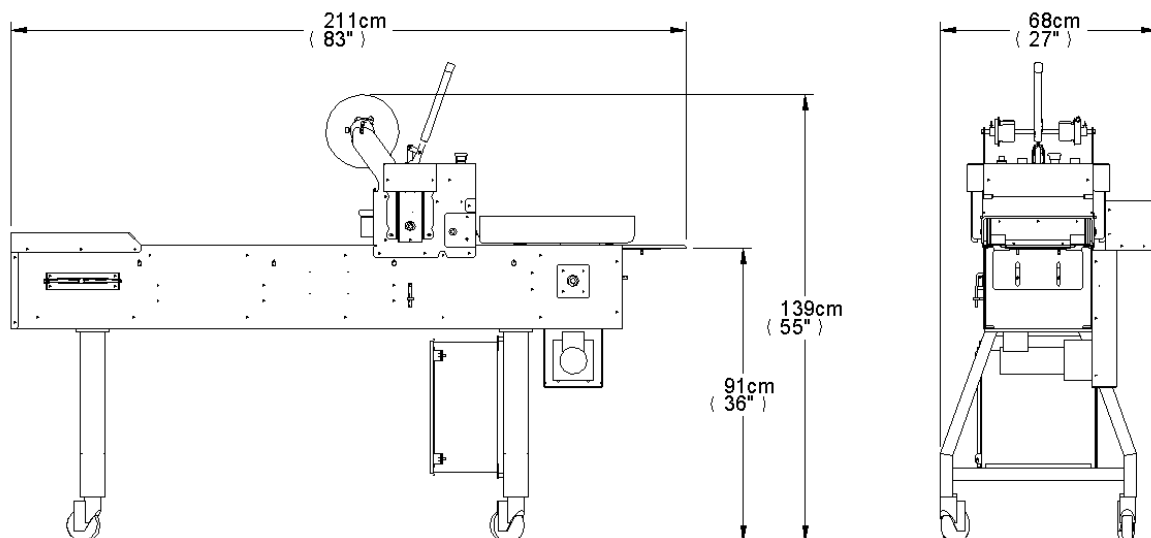



52, rue Huot  
Notre-Dame-de-l'Île-Perrot, QC  
J7V 7Z8

1 877 476-5725  
[www.solpak.ca](http://www.solpak.ca)

## ***Description (continued)***

*Standard Electrical Options: (Others consult factory).*

2 Phase, 50-60Hz, 208-240VAC, 10 Amps

*Net Weight*

154 kg (340 lbs.) (approximate)

*Shipping Weight*

181 kg (400 lbs.) (approximate)



52, rue Huot  
Notre-Dame-de-l'Île-Perrot, QC  
J7V 7Z8

1 877 476-5725  
[www.solpak.ca](http://www.solpak.ca)

## ***Installation instructions***

### **INSPECTION**

Upon receipt and prior to uncrating, inspect the exterior of the crate for damage. If damage is noted, indicate damage on the Freight Bill and immediately contact the Freight Carrier and notify them of the damage. Have a freight claim filed. This must be done at the Recipients location and not at the Shipper's location.

### **UNCRATING**

Remove the corrugated carton from the skid by removing the nails that secure the carton to the skid and carefully lift the carton up and over the machine. After removing the carton from the machine, inspect for visible damage. If damage is noted, immediately contact the freight company and file a concealed damage freight claim.

## Operating instructions

**NOTE: Conveyor motion can be stopped at any time by lowering the operating handle, or pushing the E-Stop Pushbutton (Emergency only). The E-Stop button will also turn off power to heaters. Under normal operating conditions, conveyor is stopped by Lowering Operating Handle.**

Before operating the machine make sure it is plugged into a grounded 208-240V.A.C. outlet rated for 10 AMPS. Once the machine is plugged in, the conveyor can be run using the "Operating Handle" along with the "Start" pushbutton.

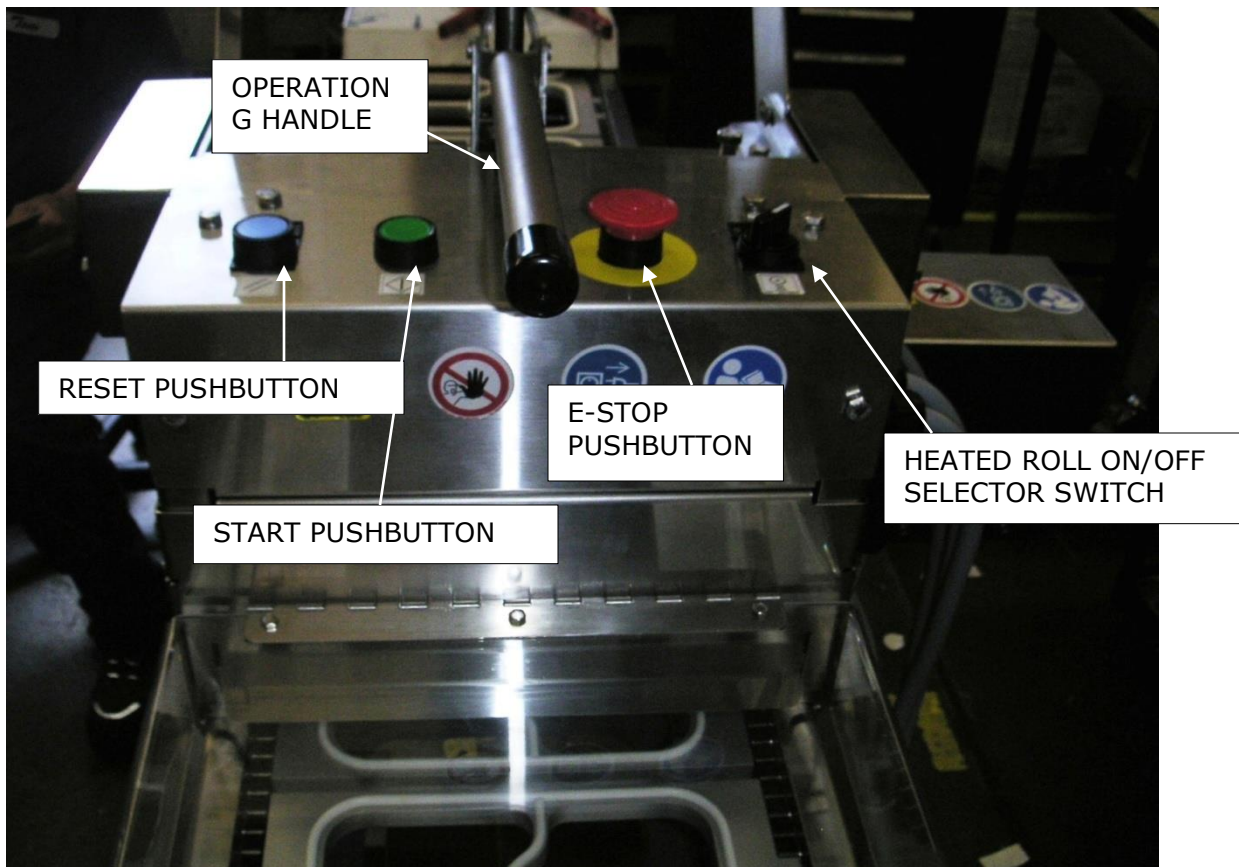

## ***Operating instructions (continued)***

The speed control knob is used to adjust the machine speed by turning clockwise to a higher number for higher speed and counter clockwise to a lower number for lower speed.



Before you are ready to run production, turn the Heated Roll "ON/OFF" ( I/O ) switch to the "ON" ( I ) position. This will supply power to the heater elements in the heat seal roll to bring it up to temperature. You should turn the power on approximately 20 minutes prior to the time you want to begin production. This will give the heat seal roll ample time to heat up. At the end of the day, turn the "ON/OFF" ( I/O ) switch to the "OFF" ( O ) position.

## Operating the machine

The conveyor can be run while the heated roll "ON/OFF" switch is in the "OFF" position. This allows for cleaning the conveyor without having the heat seal on. It is also a good idea to unplug the machine when it will not be used for a lengthy period of time.

The "RESET" switch is used to reset the machine if the guard interlock switch has been tripped or the E-Stop button is pressed. When this situation occurs, the "RESET" switch lights up indicating that one of the switches has been activated. Set the guard back to its proper position, make sure E-Stop button is released (turn anti-clockwise), then push the "RESET" switch to resume operation. If the guard has been repositioned properly, and E-Stop button is released (turn anti-clockwise), then "RESET" switch is pressed, the light on the switch will go out. The guard can be removed by pushing forward on the handle and lifting up and out. To replace the guard, drop the guard fingers into the notches and pull the handle so the interlock engages. See the photo below for the location of the guard and interlock switch.



## Operating the machine (continued)

Filled trays are manually placed in the conveyor of the machine. Film is fed from the film supply roll which must be threaded onto the machine as illustrated on the "Film Threading Diagram" which is shown in the photo below. Pull enough film so the film can be pushed down in the gap between the tray carriers. The film should hang down through the carriers about 4 to 5 inches.

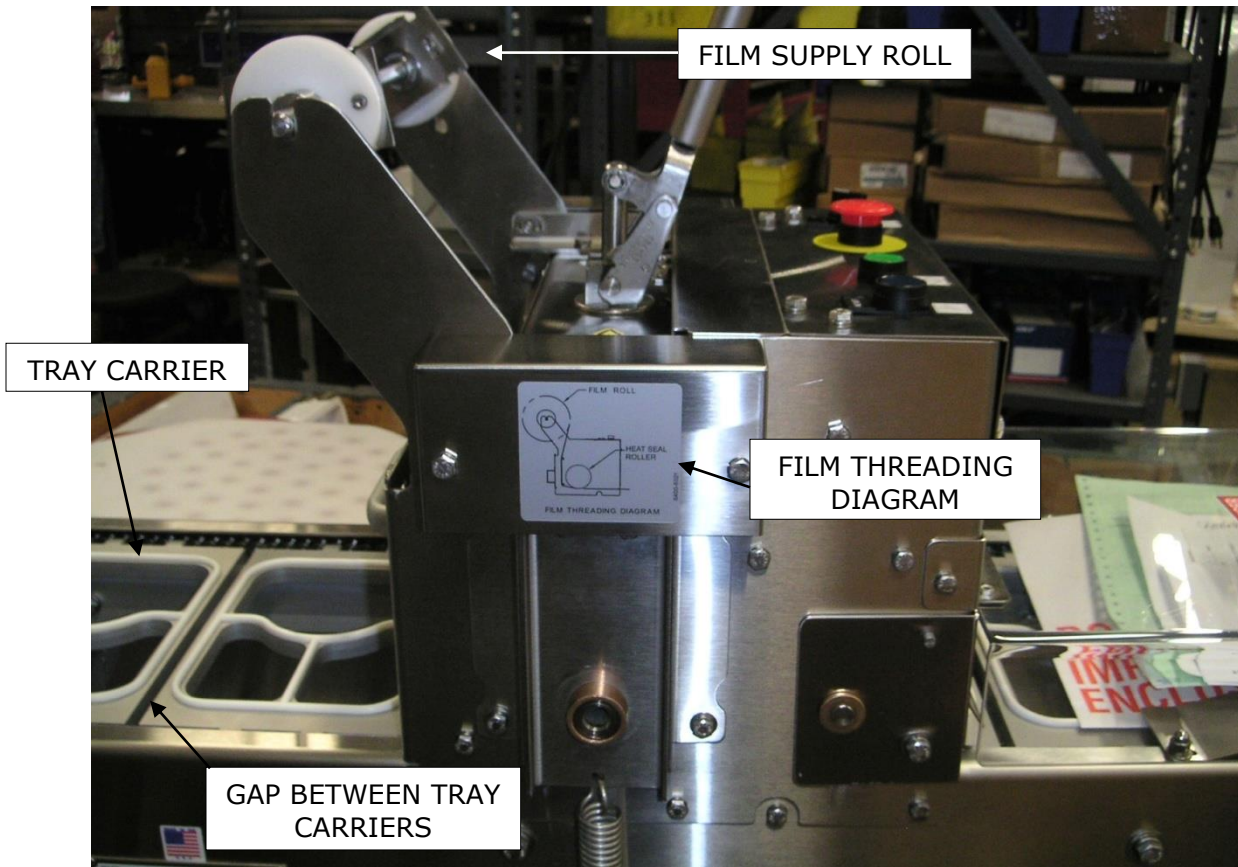

## Operating the machine (continued)

The machine is started by lifting the operating handle and pressing the START "I" pushbutton. This should be done in a swift manner which allows the heat seal roll to come into contact with tray and film quickly as the conveyor starts moving. This procedure prevents voids in the seal area during and stopping. Also, when lowering the handle to stop the machine, it should be done in swift manner as well.

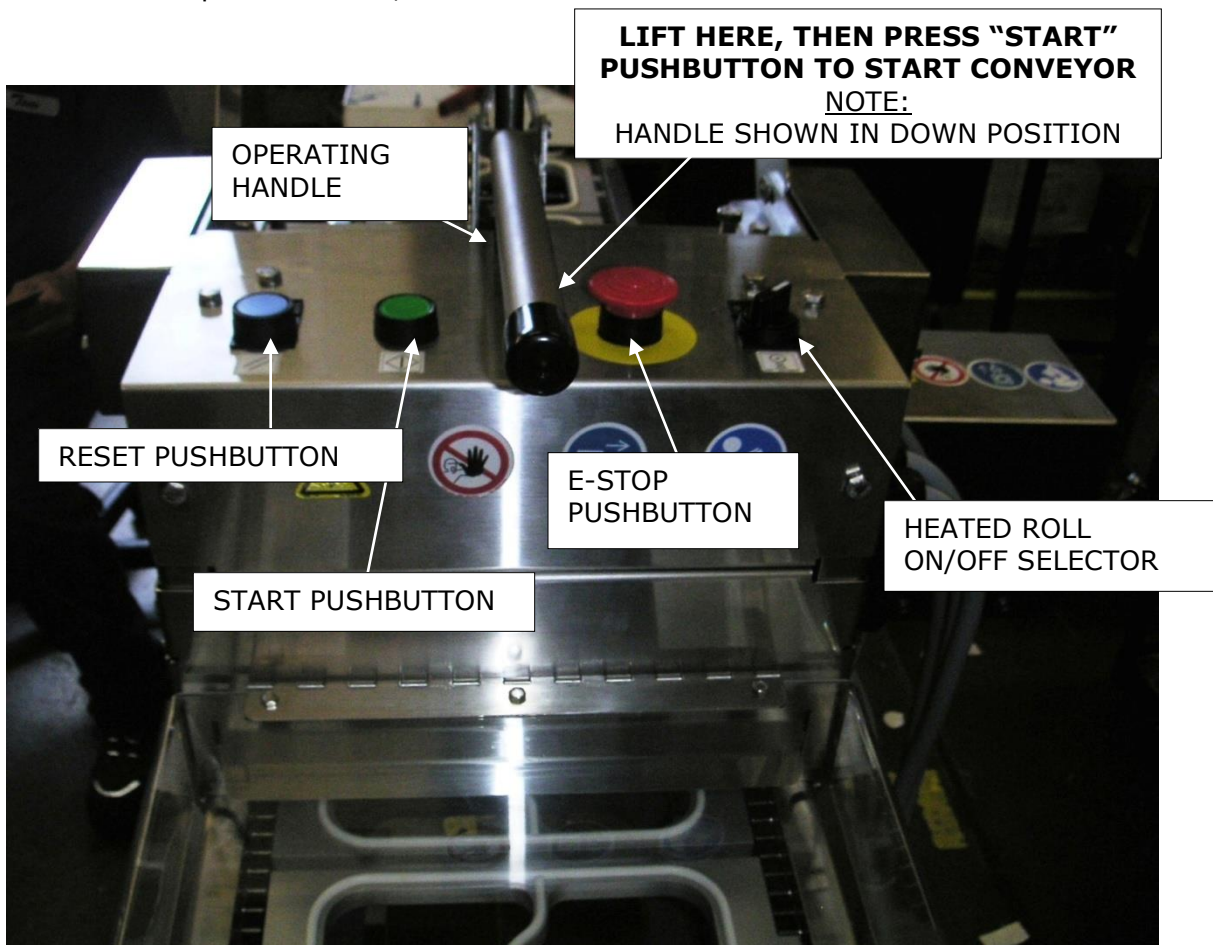

### CAUTION

**Avoid leaving the heater roll in the lowered position with the conveyor not moving. This will cause damage to the machine and any trays that are under the heated roll.**

## Operating the machine (continued)

After a few sealed trays have come off the end of the machine, check to see if the film is centered from side to side on the trays. If it is not, the film roll needs to be moved to one side or the other on the film mandrel. There are thumb screws in the stainless steel collars on each side of the film mandrel. First loosen the thumb screw on the side which the film roll needs to move toward and move that collar about one half as far as you think the film is off center and tighten the thumb screw. Then loosen the thumb screw on the other collar and move the film roll holder up against the film roll core and tighten the screw. After getting the film centered on the trays, check to see if the film is sealing to the trays without excessive wrinkles. If there are excessive wrinkles, it might be that there is not enough tension on the film roll. This can be adjusted with the three thumb screws on the plastic film roll holder. Turning the screws clockwise will increase the film tension. If the film tension is too tight and the film comes off of the roll too hard, back the screws off by turning anti-clockwise.

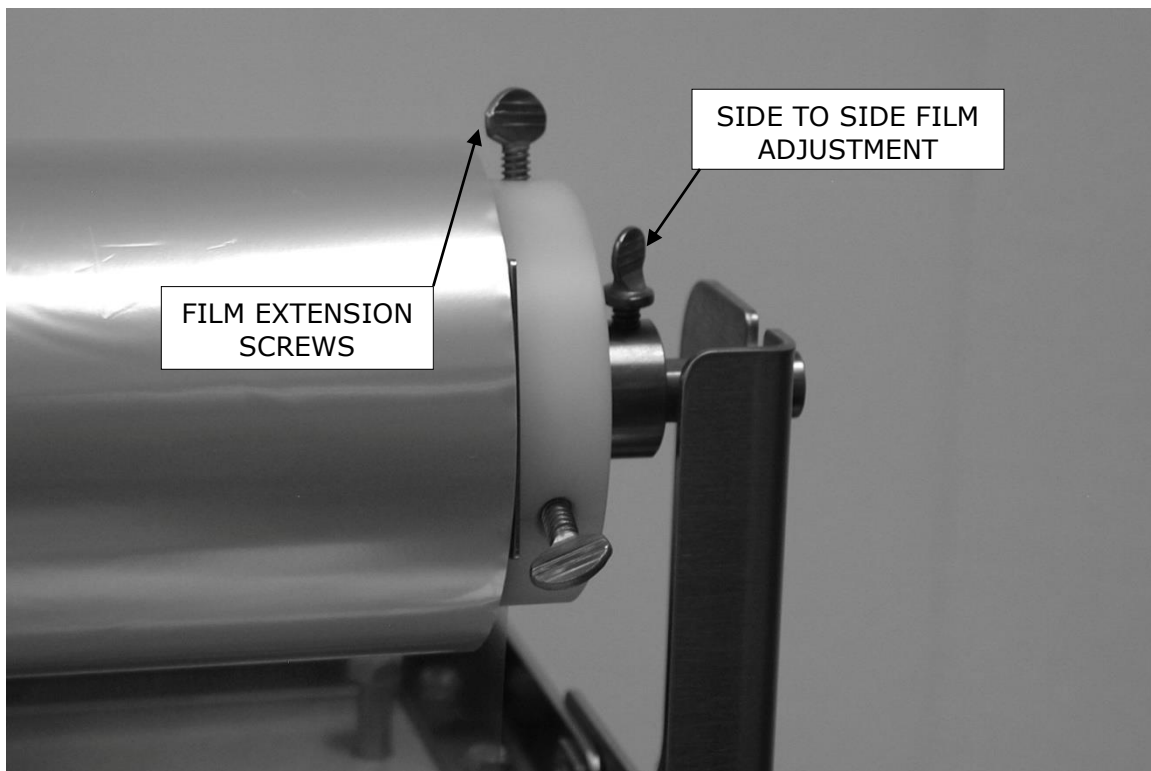

## ***Operating the machine (continued)***

As the trays come off the end of the machine, they are fed out of the tray carriers onto the discharge table. This table can be adjusted in and out and, up and down. These adjustments are shown in the photo below.

### **CAUTION**

When making either of these adjustments, care must be taken to insure that the discharge table does not get adjusted too close to the tray carriers. Doing so can cause damage to the machine.

The purpose of this adjustment is to get the trays to smoothly exit the machine as they make the transition from the tray carriers onto the table. After the trays are on the table, each tray will be pushed off the table by the next tray.

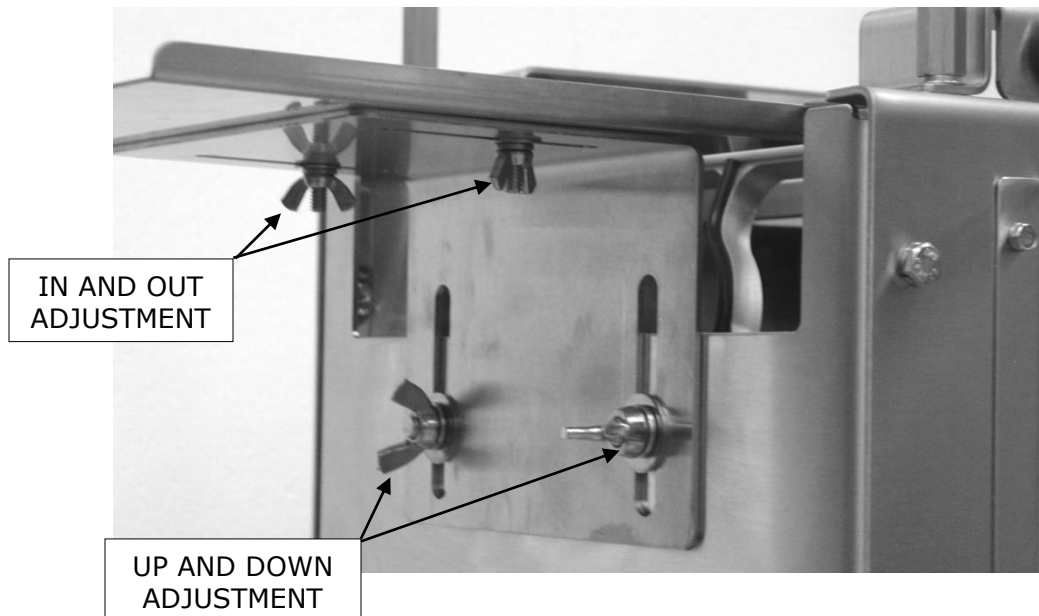

## ***Cleaning procedures***

### **WARNING**

**DISCONNECT FROM POWER BEFORE CLEANING OR SERVICING.**

### **CAUTION**

**This is not a wash-down machine! Do not directly spray any area of this machine. Clean machine areas by using only a damp rag or damp plastic scouring pad.**

Clean the Heat Seal Assembly before cleaning the Conveyor because the debris that will be removed from the Heat Seal Assembly will fall onto the Conveyor.

Inspect the Heat Seal Roll for accumulation of debris (food Product). Clean off the debris with a damp plastic scouring pad such as "Scotch Brite" brand pads.

### **CAUTION**

**Always allow heated roller to cool before cleaning Heat Seal Assembly. Do not use metallic instruments such as screwdrivers or knives to clean the Heat Seal Roll, this will cause damage to the sealing surface. Also, do not spray the Heat Seal Roll. Use only damp rags or towels to remove the loosened debris from the rolls.**

Tray carriers, if heavily soiled, can be removed for cleaning.

### **CAUTION**

**Only remove approximately one infeed section of the tray carriers at one time. Removing all the tray carriers and advancing the conveyor can cause severe damage to the machine.**

Remove the infeed section of tray carriers, wash, replace, advance conveyor, and repeat until all tray carriers have been cleaned.

**Check the corner areas of the frame for accumulation of debris that may have accumulated due to spills.**

### **NOTE**

**These cleaning recommendations are not meant to replace or supercede plant standard manufacturing procedures or regulatory requirements.**

**If Plant procedures call for the use of sanitizing solutions, use a rag dampened with the sanitizing solution after cleaning is completed.**

## ***Tray carrier (cutoff) change procedures***

### **WARNING**

**DISCONNECT FROM POWER BEFORE CLEANING OR SERVICING.**

### **CAUTION**

**Only remove approximately one infeed section of the tray carriers at one time. Removing all the tray carriers and advancing the conveyor can cause severe damage to the machine.**

## ***Tray carrier (cutoff) size change***

The machine is designed to run trays that require various cutoff lengths. The cutoff length is the dimension that the film is cut to in the machine (running) direction. The changeover between cutoff lengths consists of changing the tray carrier set and the cutter assembly.

- **Changing to a tray carrier set with the same cutoff as the previous set**

Step 1. Remove the existing tray carrier set while at the same time installing the new tray carrier set. Proceeding in this manner insures that the cutter assembly will be in time with the tray carriers and will not jam on the tray carriers. Tray carrier removal is accomplished by grasping one tray carrier in each hand while pushing on one tray carrier and pulling on the other. In doing this, the tray carriers will disengage from the pins on the conveyor chains and can be lifted out of the machine. As you remove existing tray carriers, replace them with the new ones.



## ***Tray size change (continued)***

- **Changing to a tray carrier set with a different cutoff length than the previous set**

**Step 1.** Remove the cutter assembly. Do so by removing the hex bolt from the cutter assembly side plates on both sides of the machine. Then remove the side plates by pulling them off of the shaft.

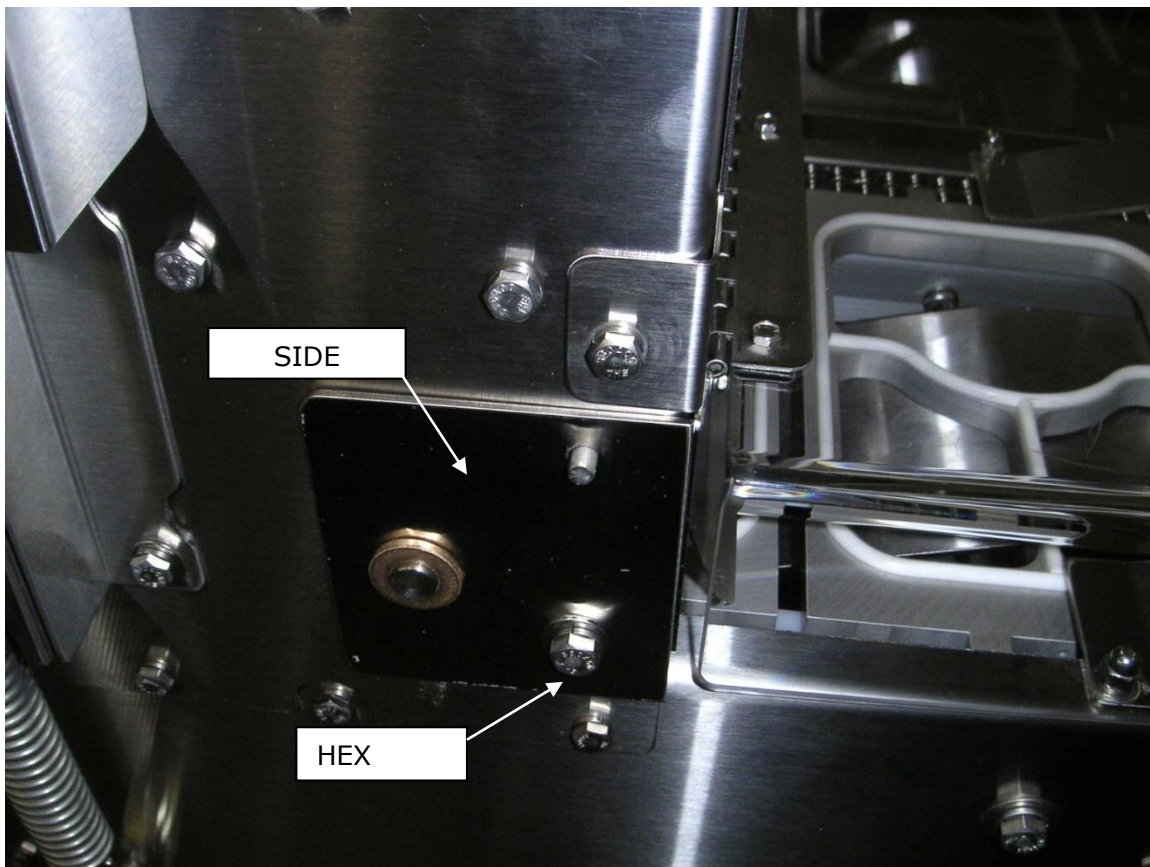

## Tray size change (continued)

### CAUTION

**THE CUTTER BLADES ARE VERY SHARP. HANDLE THEM CAREFULLY TO AVOID INJURY.**

**Step 2.** Remove the cutter assembly from the machine as shown in the photo below. Put the cutter in a safe place to prevent injury to personnel and to protect the cutter from damage.



**Step 3.** Replace the existing set of tray carriers with the new set of tray carriers.

**(See Step 1. of "Changing to a tray carrier set with the same cutoff as the previous set" on page 23)**

**Step 4.** Install the cutter assembly. **CAUTION!** You must install the cutter assembly so it is in time with the tray carriers or the blade will jam on the carriers. Run the machine slowly until a gap between tray carriers is approximately underneath the center of the cut-out in the side frame (see photo above) Insert the cutter assembly into the frame with the blade in the gap between the tray carriers. Replace the side plates and secure with the hex bolts.

## ***Maintenance procedures***

### **WARNING**

**DISCONNECT FROM POWER BEFORE CLEANING OR SERVICING.**

### **CAUTION**

**Only remove approximately one infeed section of the tray carriers at one time. Removing all the tray carriers and advancing the conveyor can cause severe damage to the machine.**

### **LUBRICATION**

The bearings used on the Model 1808 are of the type that do not require lubrication,

The conveyor main roller chains are rust resistant but an application of mineral oil periodically is recommended. Frequency varies with each application, the duty cycle and the operating environment.

### **WARNING**

**DO NOT ATTEMPT TO DO THE FOLLOWING STEP WHILE THE MACHINE IS RUNNING.**

Open chains on the drive train should be coated with a good, heavy duty (FOOD CONTACT APPROVED) bearing grease. This can be done by wiping grease on both sides of the chain. The grease will transfer from the chain to the sprockets thereby lubricating the drive train. Check chains monthly for lubrication.

### **CHAIN TENSION**

The chains should be checked for proper tension weekly.

### **DRIVE CHAINS**

The drive chain should be taught so there is little or no backlash in the drive train. The drive chain and its tensioner are located underneath the guard at the discharge end of the machine.

### **MAIN CONVEYOR CHAINS**

The main conveyor chains should be tight so as to prevent buckling of the chains as the tray carriers come around the bottom of the head shaft sprockets at the discharge end of the machine. If necessary, tighten the chains using the take-up units located at the in-feed end of the machine. If at all possible, try to tension both chains the same amount so that the chains will be in alignment with each other and the tray carriers will run down the conveyor square to the frame.

## ***Maintenance procedures (continued)***

The main drive chains are tensioned by adjusting the chain take-up units located at the in-feed end of the machine (see photo below). To tighten the chains, loosen the jam nut on the adjusting screw. Turn the adjusting nut clockwise to tighten the chains. Turn the adjusting nut ½ turn on one side of the machine and then ½ turn on the other side of the machine and check chain for tension. Proper tension is when the return tray carriers on the bottom of the conveyor can be lifted up about 1" without the chain feeling over tight. If the chain is very sloppy when lifted, it is too loose. After adjusting, tighten the jam nuts.

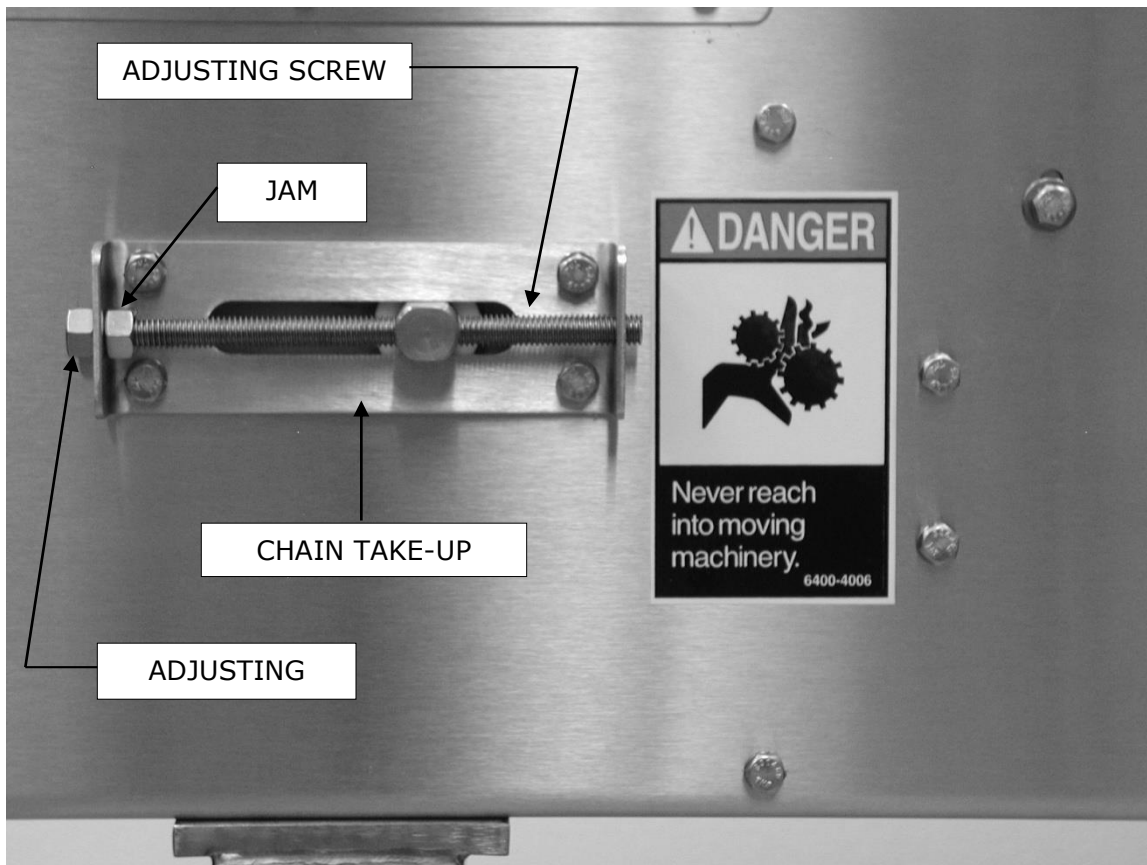

## ***Maintenance procedures (continued)***

### **CUTTER ASSEMBLY**

Check the cutter blades for sharpness and damage on a weekly basis. Replace blade(s) if necessary. The blades are easily replaced. The blades are held in place by two set-screws. Notice that the set-screws are pressing against a backer strip which in turn presses against the actual blade. The reason for this is that the blade material is very hard and if the set-screws were to press directly on the blade, the blade could possibly be cracked. So, it is important that the new blade be placed behind the backer strip and not next to the set-screws (see photo below). Loosen the two set-screws, remove the old blade, insert the new blade and tighten set-screws.

Should the cutter get out of time with the tray carriers, it can be re-timed by loosening the two set-screws in the drive sprocket and turning the cutter in the appropriate direction and tightening the set-screws (see photo below). The two set-screws are 90 degrees apart. Run the conveyor and stop in a position where you can get access to the first set-screw and loosen that screw. Then run the conveyor further until you have access to the second screw and loosen that screw. Now turn the cutter in the appropriate direction and tighten this screw. Run the conveyor until you have access to the first screw and tighten.

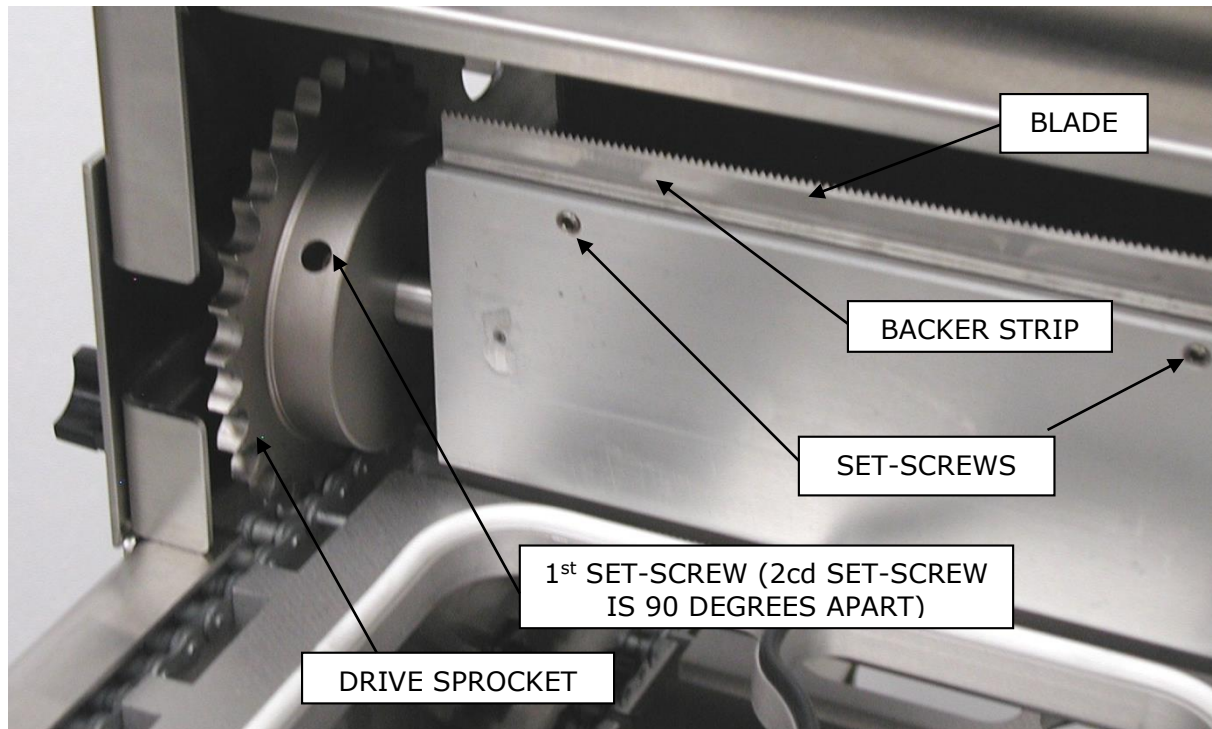

## Heat seal roll down-stroke adjustment procedures

### NOTE

Before conducting this procedure, make certain that the sleeve on the heat seal roll is clean and does not have any burnt-on food product on the surface.

Put an empty tray into the machine and run the machine until the tray is under the heat seal roll and stop the machine with the tray under the roll. Unplug the machine. Raise the operating handle and let the roll down onto the tray. There are two adjusting bolts that determine how far the heat seal roll can go down (see photo below). These bolts are there to prevent the roll from going down too far in the gap between the tray carriers or when there are no tray carriers in the machine. The dimension between the head of the bolts and the heat seal frame should be  $1/8''$  when the roll is in the down position and resting on top of a tray. To adjust the bolts, the jam nut underneath the heat seal frame must be loosened. Tighten jam nut after adjusting.

NOTE: THE HEAT ROLL IS SHOWN IN THE UP POSITION. THE OPERATING HANDLE MUST BE RAISED TO PLACE THE ROLL IN THE DOWN POSITION BEFORE SETTING THE ADJUSTMENT.

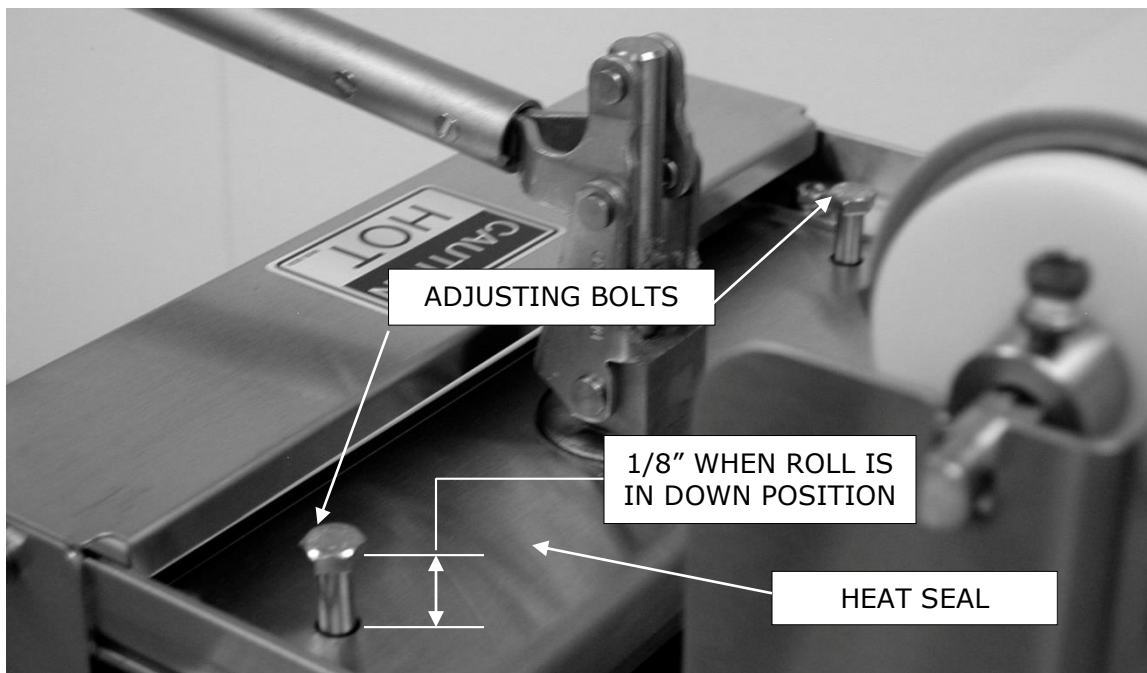

## ***Temperature adjustment***

### **WARNING**

**ONLY AN AUTHORIZED SERVICE TECHNICIAN CAN ADJUST THE TEMPERATURE OF THE HEAT SEAL ROLL.**

If the film is not sealing securely to the trays, it might be because the temperature is too low. Temperature of the heat seal roll is set to 175 degrees Celsius at the factory. Only a authorized Service Technician can adjust the temperature of the heat seal roll.

### **WARNING**

**NEVER ADJUST THE TEMPERATURE OF THE HEAT SEAL ROLL ABOVE 185 DEGREES CELSIUS.**

**ADJUSTING THE TEMPERATURE OF THE HEAT SEAL ROLL ABOVE 185 DEGREES CELSIUS CAN CAUSE A FIRE AND/OR SEVERE DAMAGE TO MACHINE.**

### **NOTE**

See TROUBLESHOOTING section of this manual before adjusting the temperature of the heat seal roll.

## ***Recommended spare parts***

<b><u>Description</u></b>	<b><u>Part No.</u></b>	<b><u>Suggested Qty.</u></b>
Fuse 500 mA (5 x 20mm)	5725-9562	4
Fuse 3 .15 Amp (5 x 20mm)	5725-9570	2
Fuse 5 Amp (5 x 20mm)	5725-9572	2
Cartridge Heater	5730-1564	4
Thermocouple	5712-0527	1
Cutter Blade	1808-0071	2

## Troubleshooting

### WARNING

**DISCONNECT FROM POWER BEFORE CLEANING OR SERVICING.**

### WARNING

**SERVICE ON THIS EQUIPMENT SHOULD ONLY BE PERFORMED BY A QUALIFIED SERVICE TECHNICIAN.**

Should you experience problems with your machine, refer to the Trouble Shooting guide below. If you have attempted the remedies listed below and are still experiencing problems, call SOLPAK at 1-877-476-5725 ext 221.

#### SYMPTOM

##### Poor seal quality

#### CORRECTIVE ACTION

Check to see that the heated roll switch is in the "I" on position.

Check to see if the heat seal roll is dirty, if so clean as detailed in the "CLEANING PROCEDURES".

Check the rubber gaskets on tray carriers for damaged or missing pieces.

Check the fuses in the electrical enclosure to see if any fuse is open (no continuity), if it is open, replace it. (To be performed only by a Qualified Service Technician)

Check to see if one or more of the heater elements are burned out. There are four heater elements in the heat seal roll. This check requires the use of an amp meter to determine the condition of each individual heater element. (To be performed only by a Qualified Service Technician)

## ***Troubleshooting (continued)***

### **SYMPTOM**

### **CORRECTIVE ACTION**

**Poor seal quality** (continued)

Make certain that the heat seal roll down stroke is adjusted correctly as explained in the "MACHINE ADJUSTMENTS" section of this manual.

**Heat seal roll does not heat**

Make certain the machine is plugged into an adequately rated electrical outlet.

Verify that there is power at the electrical outlet.

Check to see that the heated roll switch is in the "I" on position.

Check the E-stop button – must be in released position.

Check if Reset button is illuminated – press to reset.

Make certain the machine is plugged into an adequately rated electrical outlet.

Verify that there is power at the electrical outlet.

Check the fuses in the electrical enclosure to see if any fuse is open (no continuity), if it is open, replace it. (To be performed only by a Qualified Service Technician)

Check the circuit breaker in the electrical enclosure to see if it has tripped. If tripped, investigate cause and reset. (To be performed only by a Qualified Service Technician)

**Film does not cut**

Check to see if a cutter blade is missing

Check to see if cutter blade is dull

## ***Troubleshooting (continued)***

### **Film is not centered on tray**

Check to see if film roll is centered on the machine. If not, center the roll as explained in the "OPERATING THE MACHINE" section of this manual.

### **Machine does not run**

Make certain the machine is plugged into an adequately rated electrical outlet.

Verify that there is power at the electrical outlet.

Check the E-stop button – must be in released position.

Check if Reset button is illuminated – press to reset.

Check the fuses in the electrical enclosure to see if any fuse is open (no continuity), if it is open, replace it. (To be performed only by a Qualified Service Technician).

Check the circuit breaker in the electrical enclosure to see if it has tripped. If tripped, investigate cause and reset. (To be performed only by a Qualified Service Technician).

Check to see if heated roll is in sealing position (down).

## Frame and drive assembly

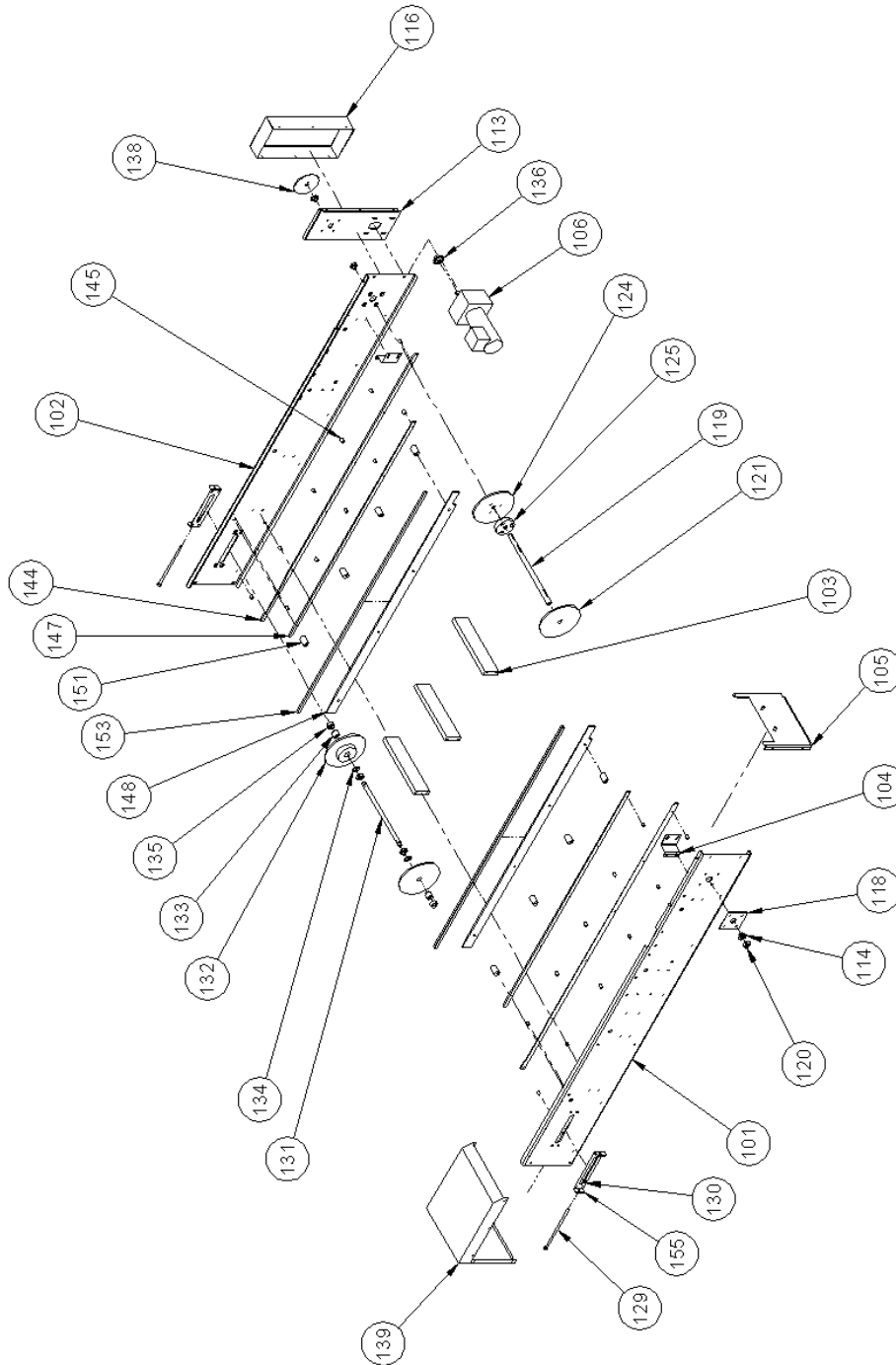

## ***Frame and drive assembly (continued)***

<b>ITEM NO</b>	<b>PART DESCRIPTION</b>	<b>PART NUMBER</b>
101	Frame Front	1808-0054-001
102	Frame Rear	1808-0055-001
103	Spacer Frame	1808-0091
104	Spacer Discharge Lift	1808-0056
105	End Plate	1808-0057
106	Gearmotor 90VDC	6310-0202
113	Plate Guard Backing	1808-0114
114	Bearing Bronze	5254-3032
116	Guard Drive	1808-0115
118	Block Bearing	1908-0055
119	Shaft Drive	1808-0028
120	Set Collar	5806-7057
121	Sprocket Plated	4618-4048-2431
124	Sprocket Adjustable	4615-4048-2431
125	Retainer Hub	1908-0053
129	Take-up Screw	1908-0005-001
131	Shaft Tail	69327
132	Sprocket	4617-4048-3231
133	Bearing Bronze	5254-0322
134	Bearing Bronze Thrust	5254-3514
135	Spacer Sprocket	1808-0027

## ***Frame and drive assembly (continued)***

<b><u>ITEM NO</u></b>	<b><u>PART DESCRIPTION</u></b>	<b><u>PART NUMBER</u></b>
136	Sprocket	4617-3514-2431
138	Sprocket	4618-3540-2431
139	Guard Infeed	1808-0026-002
144	Support Chain Lower	1808-0090-002
145	Spacer Chain Support	66240
147	Support Chain Upper	1808-0092-002
148	Strip Carrier Support	1808-0094-002
151	Spacer Tray Support	52525
153	Strip Wear UHMW	1808-0106-001
155	Take-up Frame	1908-0054-001

## Leg assembly

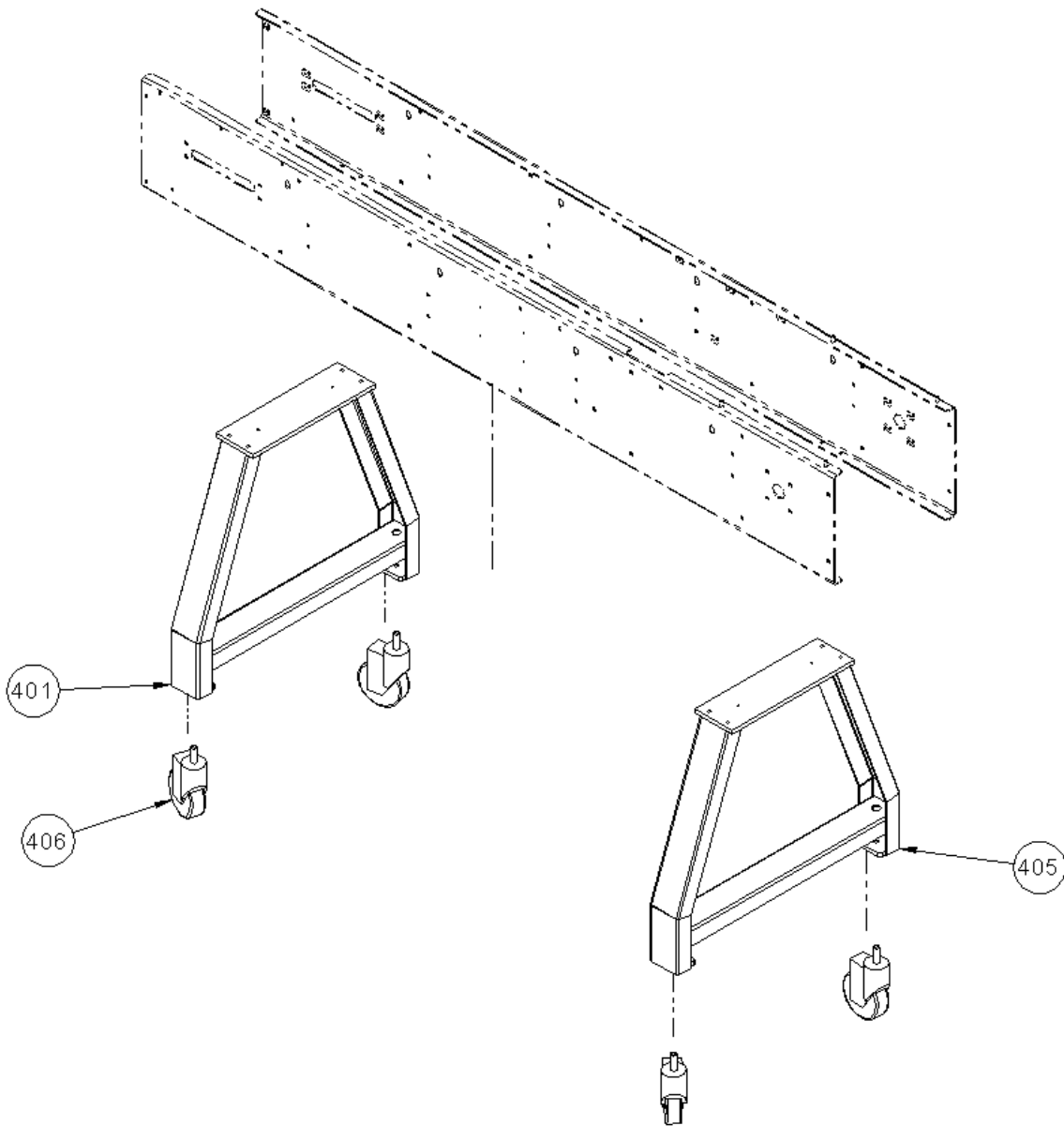

<b>ITEM NO</b>	<b>PART DESCRIPTION</b>	<b>PART NUMBER</b>
401	Leg	1808-0053
405	Leg	1808-0053-001
406	Caster	5902-2409

## Heat seal frame assembly

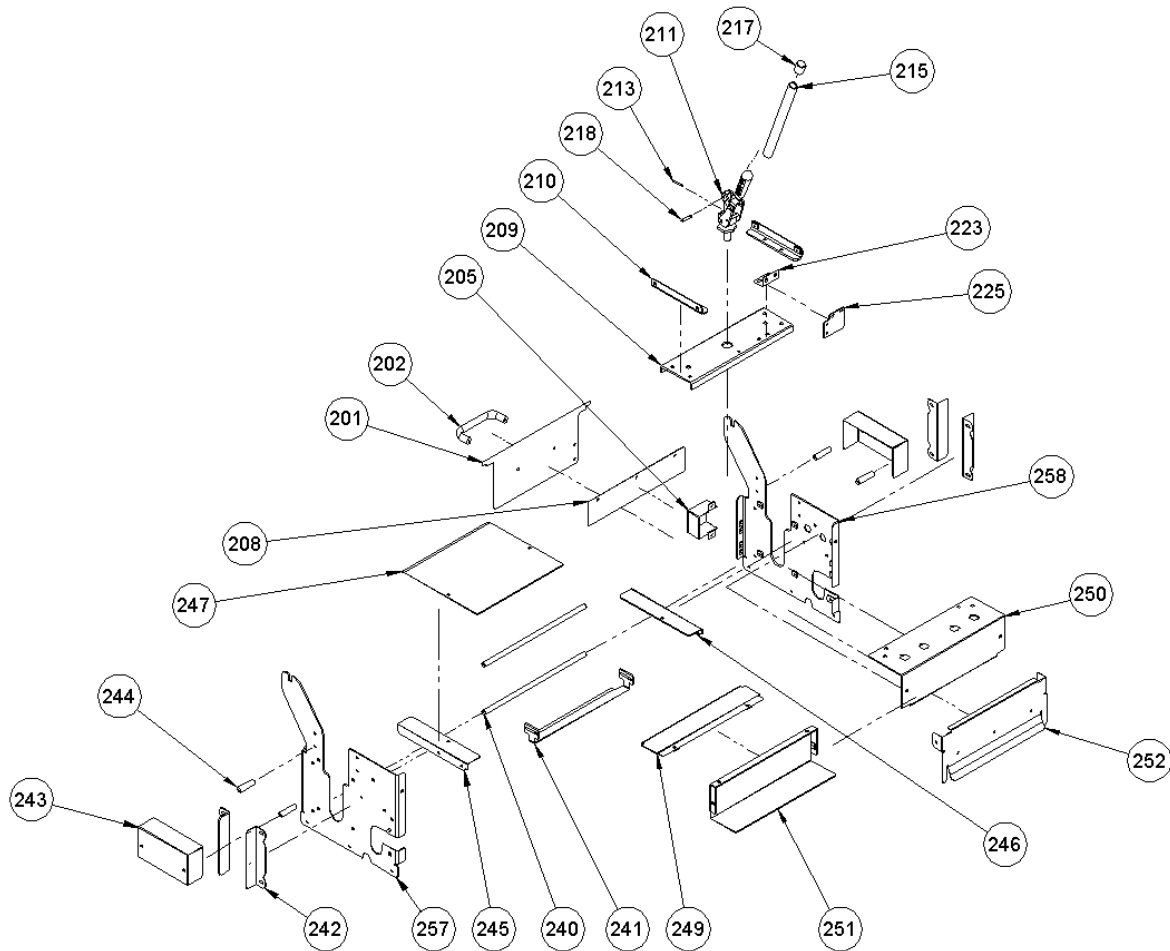

<b>ITEM NO</b>	<b>PART DESCRIPTION</b>	<b>PART NUMBER</b>
201	Door Guard	1808-0038-001
202	Handle	5908-5135
205	Cover Switch	1808-0122
208	Guard Inside	1808-0123
209	Bracket Clamp	1808-0034-001

## ***Heat seal frame assembly (continued)***

<b>ITEM NO</b>	<b>PART DESCRIPTION</b>	<b>PART NUMBER</b>
210	Bracket Angle	1808-0035
211	Clamp Toggle	1808-0065
213	Pin Spring	5835-6788
215	Handle	1808-0064
217	Cap Protective	5105-5250
218	Pin Clamp	1508-0048
223	Bracket Switch Plate	1808-0086
225	Plate Switch Mounting	1808-0085
240	Rod Film	1808-0037
241	Retainer Tray	1808-0069
242	Guide Angle Long	1808-0039-001
243	Cover Side	1808-0124
244	Spacer Cover Side	1808-0125
245	Angle Shelf Mounting (RH)	1808-0126-0001
246	Angle Shelf Mounting (LH)	1808-0126-0002
247	Shelf	1808-0042-001
249	Cover Top	1808-0127
250	Cover Top Front Pushbutton	1808-0128
251	Cover Electrical	1808-0129
252	Guard Front Hinge	1808-0044
257	Plate Frame Side (RH)	1808-0045-0021
258	Plate Frame Side (LH)	1808-0045-0022

## Heat seal roll assembly

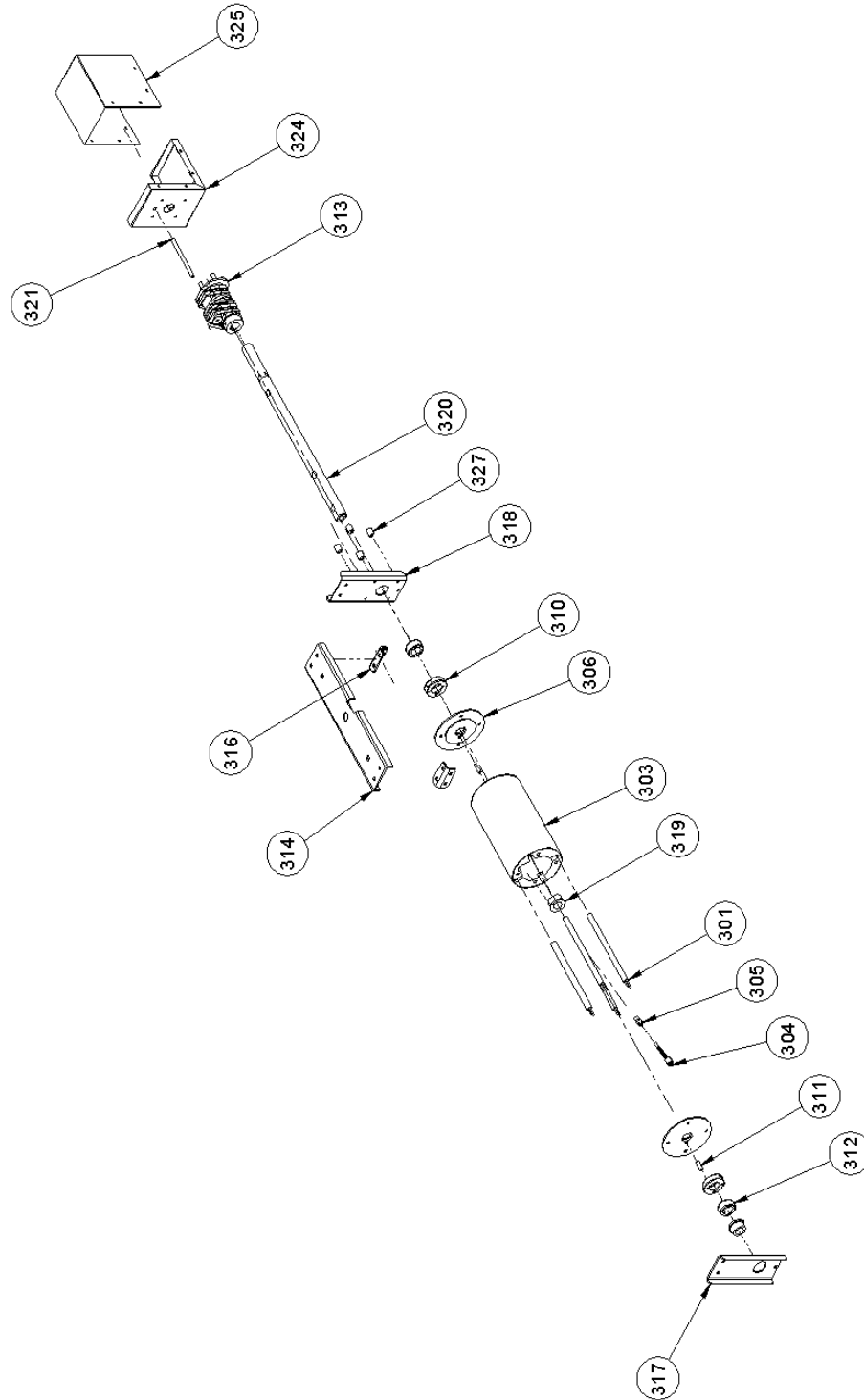

## ***Heat seal roll assembly (continued)***

<b>ITEM NO</b>	<b>PART DESCRIPTION</b>	<b>PART NUMBER</b>
301	Heater Cartridge	5730-1564
303	Roll Heat Seal	1808-0008-001
304	Thermocouple	5712-0527
305	Adapter Bayonet	5712-0597
306	Cap Retainer	1808-0010-001
310	Collar Clamp	68291
311	Pin STST	4475-0516-1
312	Set Collar	5806-7059
313	Slip Ring Assembly	5752-1040
314	Channel Upper Clamp	1808-0011
316	Mounting Support Channel	1808-0012
317	Channel End Front	1808-0013-001
318	Channel End Rear	1808-0014-001
319	Bearing Bronze	5254-3043
320	Shaft Heat Seal Roller	1808-0009-002
321	Retainer Slip Ring Rod	1808-0120
323	Guard Slip Ring Rear	1808-0016-002
324	Guard Slip Ring Cover	1808-0017-002
327	Spacer Brush Guard	1808-0015-001

## Discharge assembly

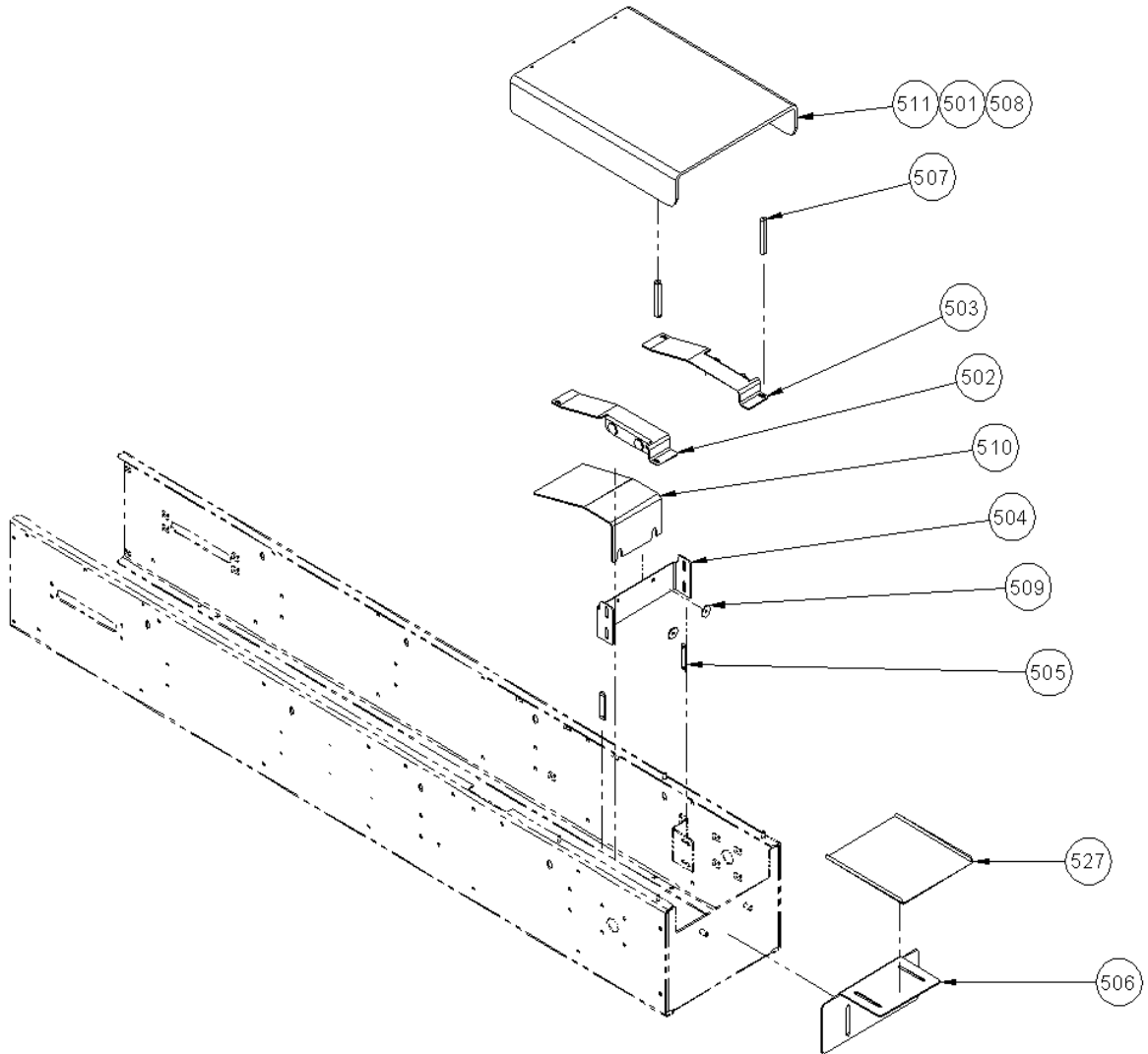

## ***Discharge assembly (continued)***

<b>ITEM NO</b>	<b>PART DESCRIPTION</b>	<b>PART NUMBER</b>
501	Strip Hinge Backer	1808-0058
502	Base Lift Tray Guide (RH)	1808-0059
503	Base Lift Tray Guide (LH)	1808-0060
504	Bracket Spacer	1808-0061
505	Nut Bar	1808-0062
506	Support Shelf	1808-0063
507	Spacer Cover	1908-0058-002
508	Hinge Piano Discharge	1908-0060
509	Retainer Lift Ramp Inside	1908-0084
510	Lift Senior Meals tray	1908-0088
511	Cover Discharge	5500-5337
527	Adjustable Guide Shelf	69043

## Film mandrel assembly

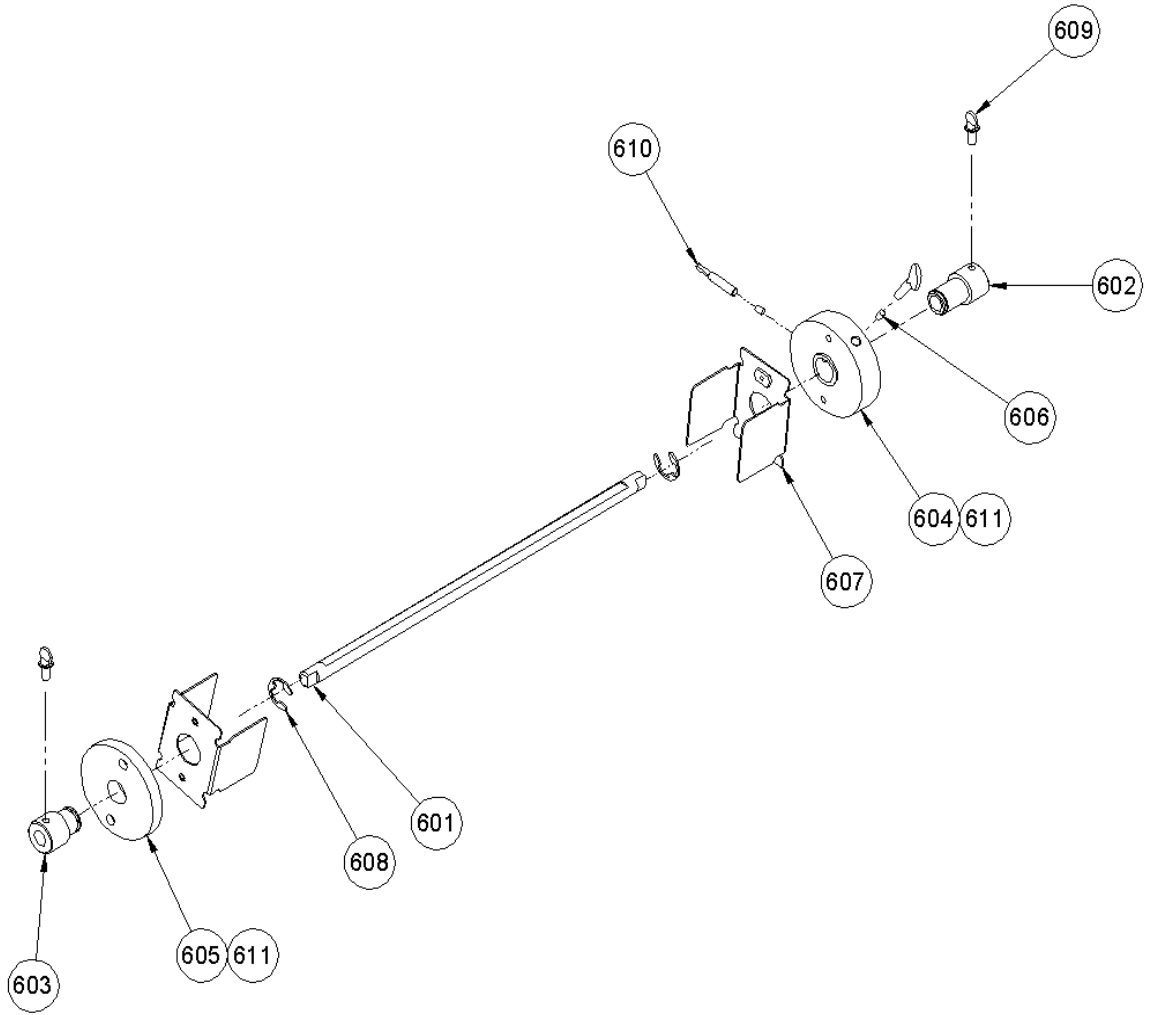

## ***Film mandrel assembly (continued)***

<b>ITEM NO</b>	<b>PART DESCRIPTION</b>	<b>PART NUMBER</b>
601	Mandrel Shaft	1808-0001
602	Retainer Film Holder Long	1808-0002
603	Retainer Film Holder Short	1808-0002-001
604	Hub Film Holder Brake	1808-0003
605	Hub Film Holder	1808-0003-001
606	Rod Brake	1808-0004
607	Holder Film	69853
608	Ring Retaining	5840-1287
609	Screw Thumb w/shoulder	5843-0536
610	Screw Thumb	5843-0538
611	Screw Cap	5843-1531
612	Screw Hex Socket	5843-1533

## Electrical assembly

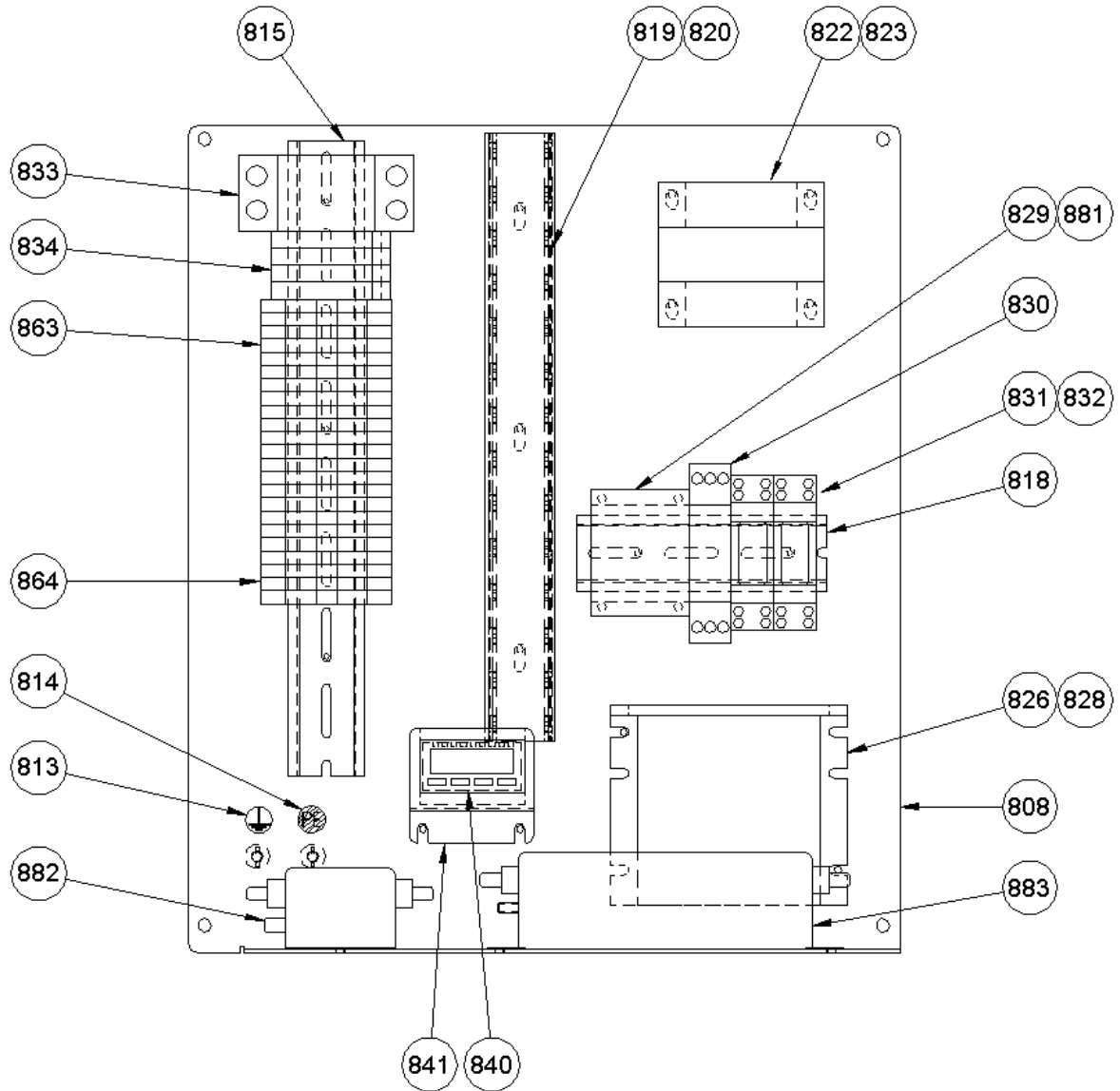

## Electrical assembly

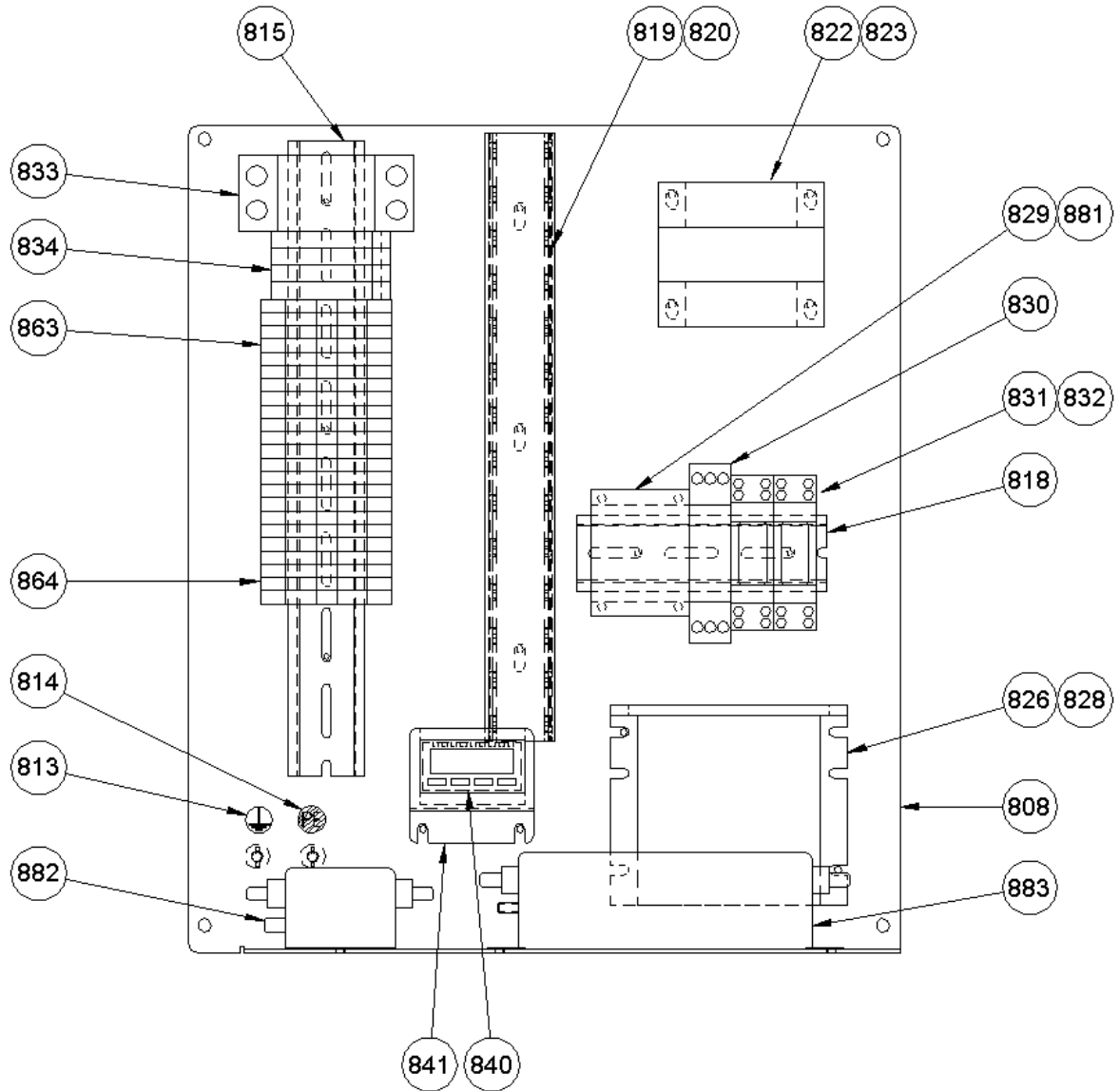

## ***Electrical assembly (continued)***

<b>ITEM NO</b>	<b>PART DESCRIPTION</b>	<b>PART NUMBER</b>
801*	Enclosure Electrical	5720-4352
802*	Spacer Enclosure	1808-0051
808	Panel Electrical Sub	1808-0121
813	Nameplate Ground	6400-7002
814	Nameplate Protective Earth Ground	6401-6040
815	Rail DIN Mounting	4516-3507-0084
818	Rail DIN Mounting	4516-3507-0036
819	Cover Wireduct	5771-6250
820	Wireduct	5771-6251
822	Transformer	5760-3043
823	Cover-Touch Safe	5760-4225
826	Control DC Motor	6309-6010
828	Resistor	6309-6013
829	Contacteur 3 Pole	5749-8289
830	Relay Electronic	5749-7005
831	Relay DPDT	5749-5638
832	Socket Relay	5770-2890
833	Circuit Breaker 2 Pole	5706-9010
834	Holder Fuse	5726-1251
835*	Fuse 5 x 20mm 500MA	5725-9562
836*	Fuse 5 x 20mm 5A	5725-9572
837*	Fuse 5 x 20mm 3.15A	5725-9570

\* = Not shown

A-MANUAL-1808CE-2015-12-11

Renseignez-vous sur nos solutions de transport uniques au Canada  
Ask us about our delivery solutions, unique in Canada

## ***Electrical diagram***

**WARNING**

**DISCONNECT FROM POWER BEFORE CLEANING OR SERVICING.**

**2 Phase, 50-60Hz, 208-240VAC**

**Ref. 1808C12003**

**SEE FOLLOWING PAGE**

# Electrical diagram (continued)

## 1808C12003

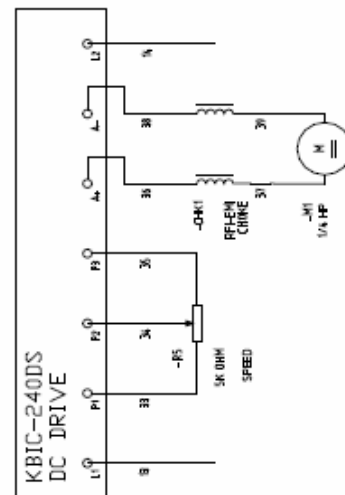
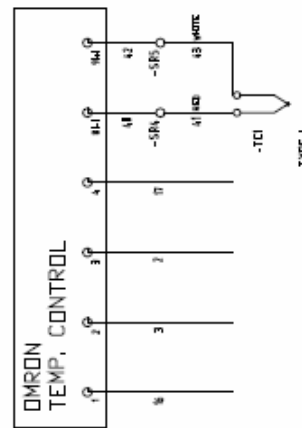
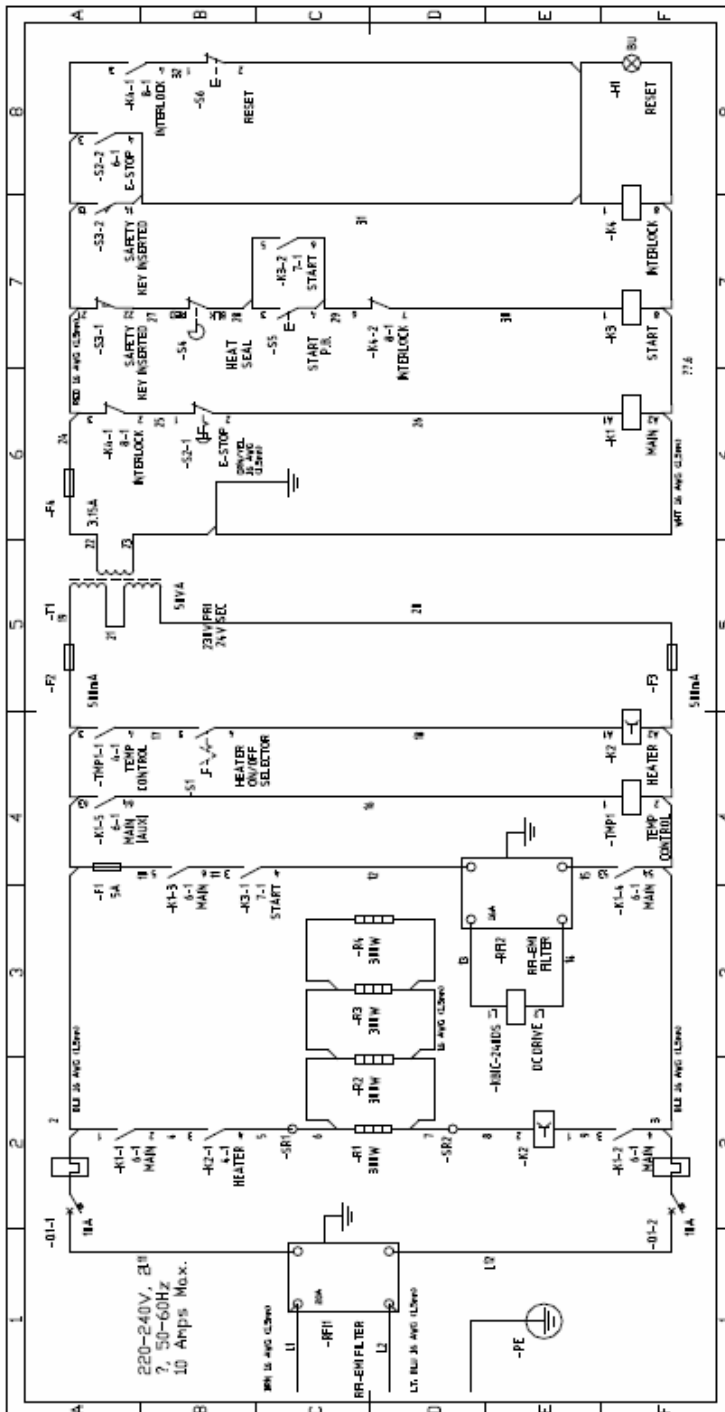

## Warranty



### PARTS

Oliver Packaging & Equipment Company (Oliver) warrants that if any part of the equipment (other than a part not manufactured by Oliver) proves to be defective (as defined below) within one year after shipment, and if Buyer returns the defective part to Oliver within one year, Freight Prepaid to Oliver's plant in Grand Rapids, MI, then Oliver, shall, at Oliver's option, either repair or replace the defective part, at Oliver's expense.

### LABOR

Oliver further warrants that equipment properly installed in accordance with our special instructions, which proves to be defective in material or workmanship under normal use within one (1) year from installation or one (1) year and three (3) months from actual shipment date, whichever date comes first, will be repaired by Oliver or an Oliver Authorized Service Dealer, in accordance with Oliver's published Service Schedule.

For purposes of this warranty, a defective part or defective equipment is a part or equipment which is found by Oliver to have been defective in materials workmanship, if the defect materially impairs the value of the equipment to Buyer. Oliver has no obligation as to parts or components not manufactured by Oliver, but Oliver assigns to Buyer any warranties made to Oliver by the manufacturer thereof.

This warranty **does not** apply to:

1. Damage caused by shipping or accident.
2. Damage resulting from improper installation or alteration.
3. Equipment misused, abused, altered, not maintained on a regular basis, operated carelessly, or used in abnormal conditions.
4. Equipment used in conjunction with products of other manufacturers unless such use is approved by Oliver Products in writing.
5. Periodic maintenance of equipment, including but not limited to lubrication, replacement of wear items, and other adjustments required due to installation, set up, or normal wear.
6. Losses or damage resulting from malfunction.

The foregoing warranty is in lieu of all other warranties expressed or implied AND OLIVER MAKES NO WARRANTY OF MERCHANTABILITY OR FITNESS FOR PURPOSE REGARDING THE EQUIPMENT COVERED BY THIS WARRANTY. Oliver neither assumes nor authorizes any person to assume for it any other obligations or liability in connection with said equipment. OLIVER SHALL NOT BE LIABLE FOR LOSS OF TIME, INCONVENIENCE, COMMERCIAL LOSS, INCIDENTAL OR CONSEQUENTIAL DAMAGES.



52, rue Huot  
Notre-Dame-de-l'Île-Perrot, QC  
J7V 7Z8

1 877 476-5725  
[www.solpak.ca](http://www.solpak.ca)

## ***Warranty procedure***

1. If a problem should occur, call SOLPAK at 1-877-476-5725 ext. 221
2. A Solpak partner will determine if the warranty will apply to this particular problem and inform you of the actions to take (technician, exchange,...).
3. Please use your 1308 backup until your 1808-CE has been repaired.

***The Solpak team  
thanks you for your trust!***